

Valve Description

- 2A - SCCA-LBN Sequence valve, unlocks the door before it opens
- 2B - SCCA-LBN Sequence valve, closes the door before it locks
- 3 - Relief valve, lowers oil pressure after the locks open to protect the stops
- 4 - Needle valve, manual override to close the door in case of an emergency

Valve settings

- 2A - 3 3/4 Turns in from all the way out
- 2B - 4 1/4 Turns in from all the way out
- 3 - 3 Turns in from all the way out

The 3 hoses that are shown in colors Blue, Green and Black are for identification purpose only

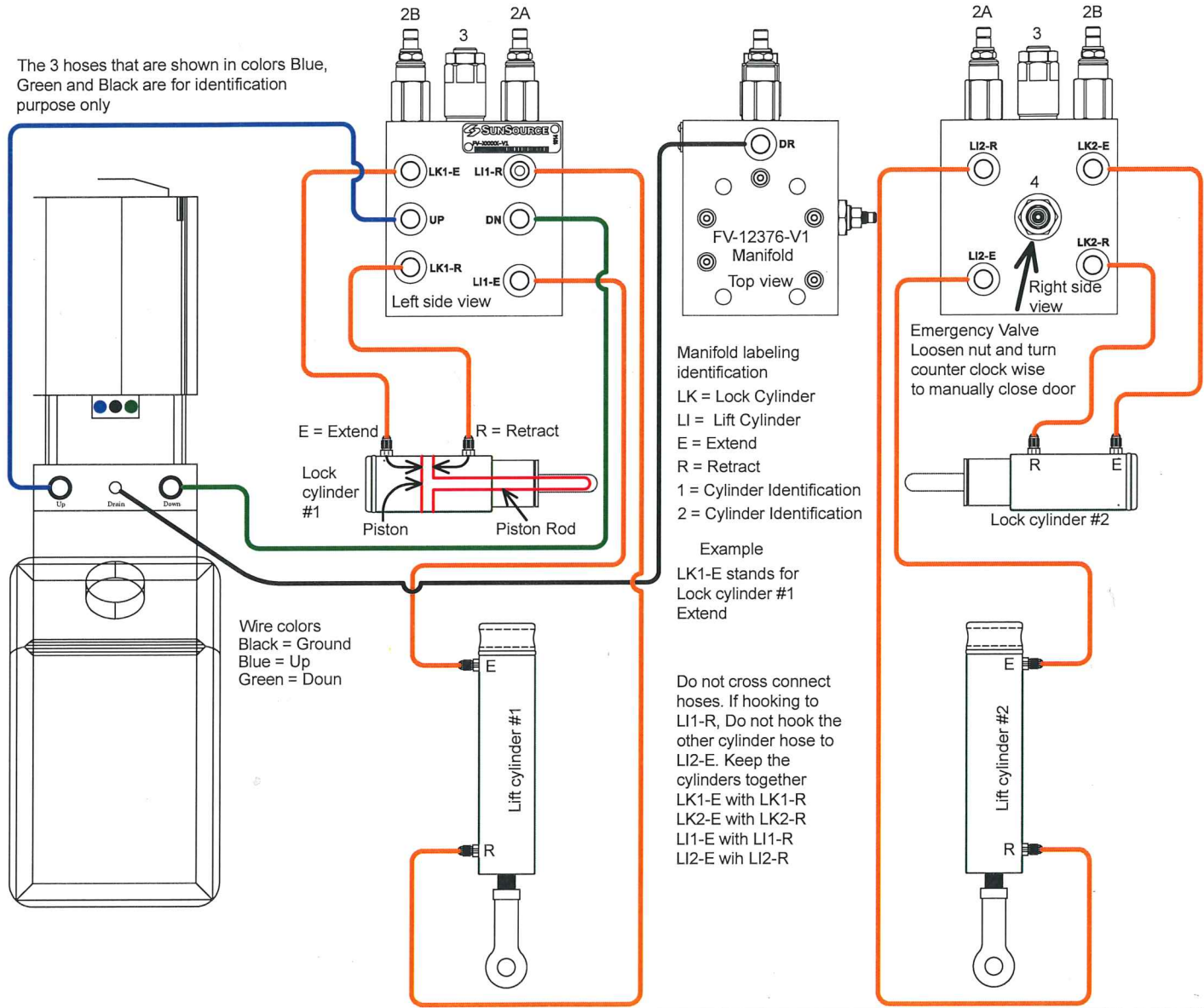

Manifold labeling identification
 LK = Lock Cylinder
 LI = Lift Cylinder
 E = Extend
 R = Retract
 1 = Cylinder Identification
 2 = Cylinder Identification

Example
 LK1-E stands for
 Lock cylinder #1
 Extend

Do not cross connect hoses. If hooking to LI1-R, Do not hook the other cylinder hose to LI2-E. Keep the cylinders together
 LK1-E with LK1-R
 LK2-E with LK2-R
 LI1-E with LI1-R
 LI2-E with LI2-R

Emergency Valve
 Loosen nut and turn counter clock wise to manually close door